

RELIABILITY REPORT
FOR
MAX3238ExAI
PLASTIC ENCAPSULATED DEVICES

June 15, 2003

MAXIM INTEGRATED PRODUCTS

120 SAN GABRIEL DR.

SUNNYVALE, CA 94086

Written by



Jim Pedicord
Quality Assurance
Reliability Lab Manager

Reviewed by



Bryan J. Preeshl
Quality Assurance
Executive Director

Conclusion

The MAX3238E successfully meets the quality and reliability standards required of all Maxim products. In addition, Maxim's continuous reliability monitoring program ensures that all outgoing product will continue to meet Maxim's quality and reliability standards.

Table of Contents

I.Device Description	V.Quality Assurance Information
II.Manufacturing Information	VI.Reliability Evaluation
III.Packaging Information	IV.Die Information
Attachments

I. Device Description

A. General

The MAX3238E transceiver uses Maxim's revolutionary AutoShutdown Plus™ feature to achieve 10nA supply current. This device shuts down the on-board power supply and drivers when they do not sense a valid signal transition on either the receiver or transmitter inputs. This occurs if the RS-232 cable is disconnected or if the transmitters of the connected peripheral are turned off. The device turns on again when a valid transition is applied to any RS-232 receiver or transmitter input. AutoShutdown Plus automatically achieves this power savings through its on-board circuitry, as no changes are required to the existing BIOS or operating system. All RS-232 inputs and outputs, as well as the logic I/O pins, have enhanced ESD protection to $\pm 15\text{kV}$. The additional ESD protection on the logic I/O pins makes the MAX3238E ideal for cell phone data cable applications because it eliminates the need for costly external TransZorb™ or protection schemes. The MAX3238E contains five drivers and three receivers and is a 3V-powered EIA/TIA-232 and V.28/V.24 communication interface intended for cell phones, data cables, and modem applications. A proprietary, high efficiency, dual charge-pump power supply and a low-dropout transmitter combine to deliver true RS-232 performance from a single +3.0V to +5.5V supply. A guaranteed data rate of 250kbps provides compatibility with popular software for communicating with personal computers. The MAX3238E has standard logic thresholds. The transmitter inputs, FORCEON, and /FORCEOFF have a 400kOhms active positive feedback resistor. Once driven to a valid logic level, it will retain this level if the driving signal is removed or goes high impedance. Unused transmitter and logic inputs may be left unconnected. The MAX3238E can operate with supply voltages ranging from +3.0V to +5.5V.

B. Absolute Maximum Ratings

<u>Item</u>	<u>Rating</u>
V _{CC}	-0.3V to +6V
V+ (Note 1)	-0.3V to +7V
V- (Note 1)	+0.3V to -7V
V+ + V- (Note 1)	+13V
Input Voltages	
T_IN, /FORCEOFF, FORCEON	-0.3V to +6V
R_IN	$\pm 25\text{V}$
Output Voltages	
T_OUT	$\pm 13.2\text{V}$
R_OUT, /INVALID	0.3V to (V _{CC} + 0.3V)
Short-Circuit Duration	
T_OUT (one at a time)	Continuous
Continuous Power Dissipation (TA = +70°C)	
28-Pin SSOP	762mW
Derate above +70°C	
28-Pin SSOP	9.52mW/°C
Operating Temperature Ranges	
MAX3238ECAI	0°C to +70°C
MAX3238EEAI	-40°C to +85°C
Storage Temperature Range	-65°C to +150°C
Lead Temperature (soldering, 10s)	+300°C

Note 1: V+ and V- can have a maximum magnitude of +7V, but their absolute difference can not exceed +13V.

II. Manufacturing Information

- A. Description/Function: +3.0V to +5.5V, 10nA, 250kbps RS-232 Transceiver with ± 15 kV ESD-Protected I/O and Logic Pins.
- B. Process: S3 (Standard 3 micron silicon gate CMOS)
- C. Number of Device Transistors: 2110
- D. Fabrication Location: Oregon, USA
- E. Assembly Location: Philippines or Malaysia
- F. Date of Initial Production: January, 2000

III. Packaging Information

- A. Package Type: **28-Pin SSOP**
- B. Lead Frame: Copper
- C. Lead Finish: Solder Plate
- D. Die Attach: Silver-filled Epoxy
- E. Bondwire: Gold (1 mil dia.)
- F. Mold Material: Epoxy with silica filler
- G. Assembly Diagram: # 05-1901-0233
- H. Flammability Rating: Class UL94-V0
- I. Classification of Moisture Sensitivity per JEDEC standard JESD22-112: Level 1

IV. Die Information

- A. Dimensions: 144 x 190 mils
- B. Passivation: $\text{Si}_3\text{N}_4/\text{SiO}_2$ (Silicon nitride/ Silicon dioxide)
- C. Interconnect: Aluminum/Si (Si = 1%)
- D. Backside Metallization: None
- E. Minimum Metal Width: 3 microns (as drawn)
- F. Minimum Metal Spacing: 3 microns (as drawn)
- G. Bondpad Dimensions: 5 mil. Sq.
- H. Isolation Dielectric: SiO_2
- I. Die Separation Method: Wafer Saw

V. Quality Assurance Information

- A. Quality Assurance Contacts: Jim Pedicord (Reliability Lab Manager)
Bryan Preeshl (Executive Director)
Kenneth Huening (Vice President)
- B. Outgoing Inspection Level: 0.1% for all electrical parameters guaranteed by the Datasheet.
0.1% For all Visual Defects.
- C. Observed Outgoing Defect Rate: < 50 ppm
- D. Sampling Plan: Mil-Std-105D

VI. Reliability Evaluation

A. Accelerated Life Test

The results of the 135°C biased (static) life test are shown in **Table 1**. Using these results, the Failure Rate (λ) is calculated as follows:

$$\lambda = \frac{1}{\text{MTTF}} = \frac{1.83}{192 \times 4389 \times 240 \times 2} \quad (\text{Chi square value for MTTF upper limit})$$

▲
Temperature Acceleration factor assuming an activation energy of 0.8eV

$$\lambda = 4.52 \times 10^{-9}$$

$$\lambda = 4.52 \text{ F.I.T. (60\% confidence level @ 25°C)}$$

This low failure rate represents data collected from Maxim's reliability monitor program. In addition to routine production Burn-In, Maxim pulls a sample from every fabrication process three times per week and subjects it to an extended Burn-In prior to shipment to ensure its reliability. The reliability control level for each lot to be shipped as standard product is 59 F.I.T. at a 60% confidence level, which equates to 3 failures in an 80 piece sample. Maxim performs failure analysis on any lot that exceeds this reliability control level. Attached Burn-In Schematic (Spec. # 06-5198) shows the static Burn-In circuit. Maxim also performs quarterly 1000 hour life test monitors. This data is published in the Product Reliability Report (**RR-1M**).

B. Moisture Resistance Tests

Maxim pulls pressure pot samples from every assembly process three times per week. Each lot sample must meet an LTPD = 20 or less before shipment as standard product. Additionally, the industry standard 85°C/85%RH testing is done per generic device/package family once a quarter.

C. E.S.D. and Latch-Up Testing

The RS76-1 die type has been found to have all pins able to withstand a transient pulse of $\pm 2500\text{V}$, per Mil-Std-883 Method 3015 (reference attached ESD Test Circuit). Latch-Up testing has shown that this device withstands a current of $\pm 250\text{mA}$.

Table 1
Reliability Evaluation Test Results

MAX3238ExAI

TEST ITEM	TEST CONDITION	FAILURE IDENTIFICATION	PACKAGE	SAMPLE SIZE	NUMBER OF FAILURES
Static Life Test (Note 1)					
	Ta = 135°C Biased Time = 192 hrs.	DC Parameters & functionality		240	0
Moisture Testing (Note 2)					
Pressure Pot	Ta = 121°C P = 15 psi. RH= 100% Time = 168hrs.	DC Parameters & functionality	SSOP	77	0
85/85	Ta = 85°C RH = 85% Biased Time = 1000hrs.	DC Parameters & functionality		77	0
Mechanical Stress (Note 2)					
Temperature Cycle	-65°C/150°C 1000 Cycles Method 1010	DC Parameters		77	0

Note 1: Life Test Data may represent plastic DIP qualification lots.

Note 2: Generic Package/Process data

Attachment #1

TABLE II. Pin combination to be tested. 1/ 2/

	Terminal A (Each pin individually connected to terminal A with the other floating)	Terminal B (The common combination of all like-named pins connected to terminal B)
1.	All pins except V_{PS1} 3/	All V_{PS1} pins
2.	All input and output pins	All other input-output pins

1/ Table II is restated in narrative form in 3.4 below.

2/ No connects are not to be tested.

3/ Repeat pin combination I for each named Power supply and for ground

(e.g., where V_{PS1} is V_{DD} , V_{CC} , V_{SS} , V_{BB} , GND, $+V_S$, $-V_S$, V_{REF} , etc).

3.4 Pin combinations to be tested.

- Each pin individually connected to terminal A with respect to the device ground pin(s) connected to terminal B. All pins except the one being tested and the ground pin(s) shall be open.
- Each pin individually connected to terminal A with respect to each different set of a combination of all named power supply pins (e.g., V_{SS1} , or V_{SS2} or V_{SS3} or V_{CC1} , or V_{CC2}) connected to terminal B. All pins except the one being tested and the power supply pin or set of pins shall be open.
- Each input and each output individually connected to terminal A with respect to a combination of all the other input and output pins connected to terminal B. All pins except the input or output pin being tested and the combination of all the other input and output pins shall be open.

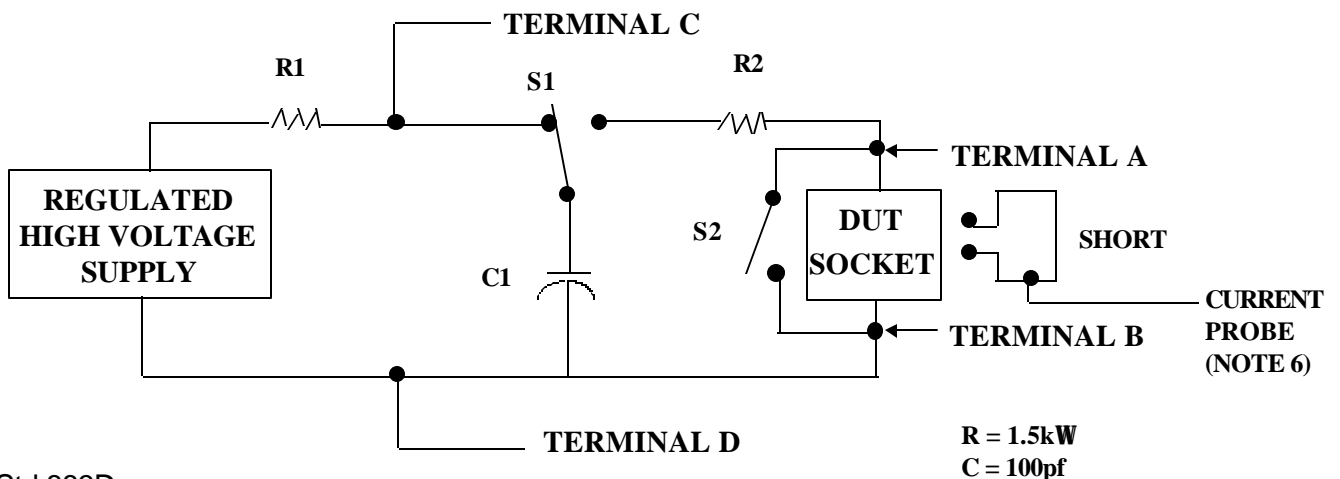

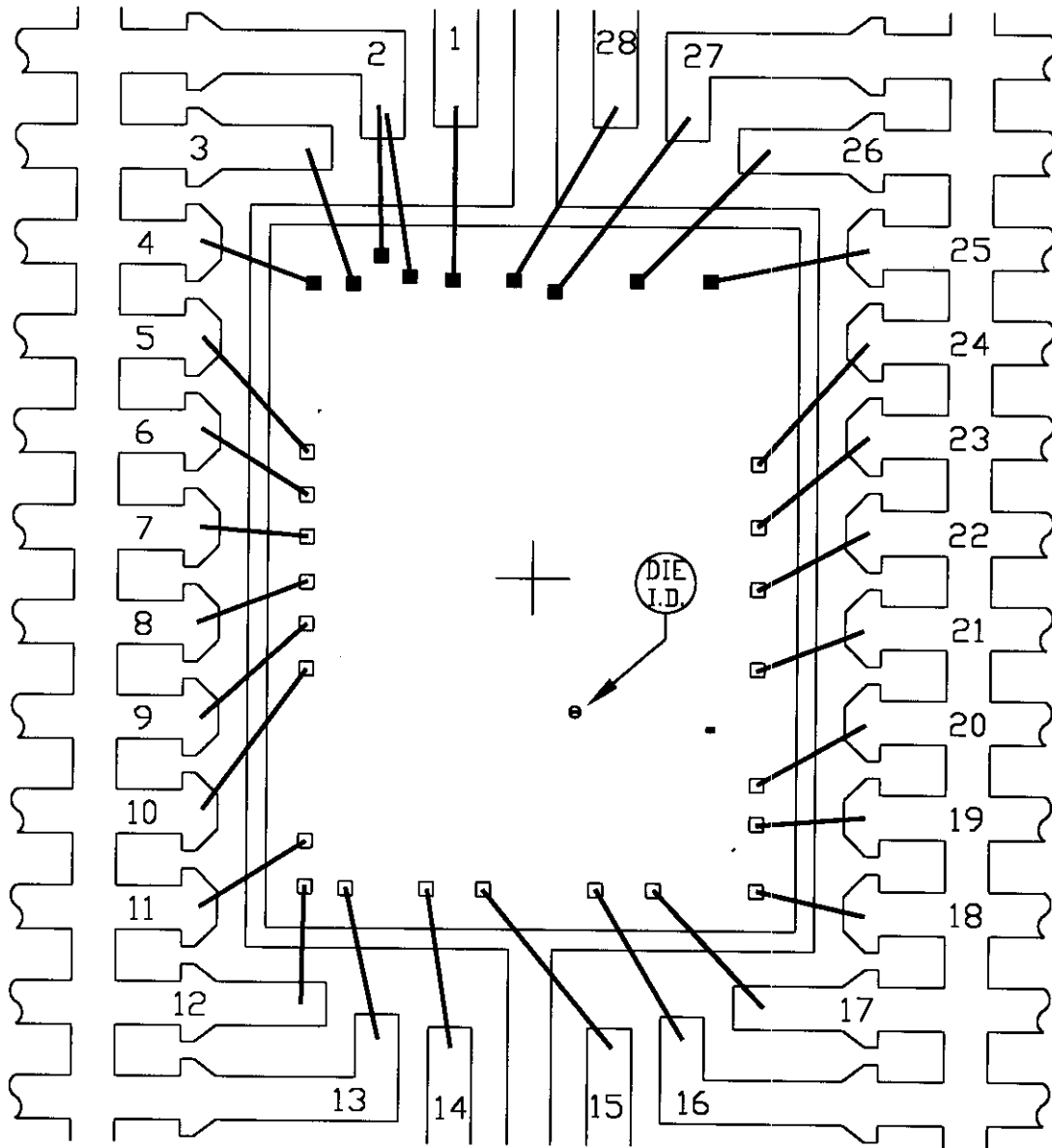

PKG.CODE: A28-1

CAV./PAD SIZE:
154X200

APPROVALS

DATE

MAXIM

PKG.
DESIGN

BUILDSHEET NUMBER: 05-1901-0233
REV: A

ONCE PER BOARD

ONCE PER DEVICE

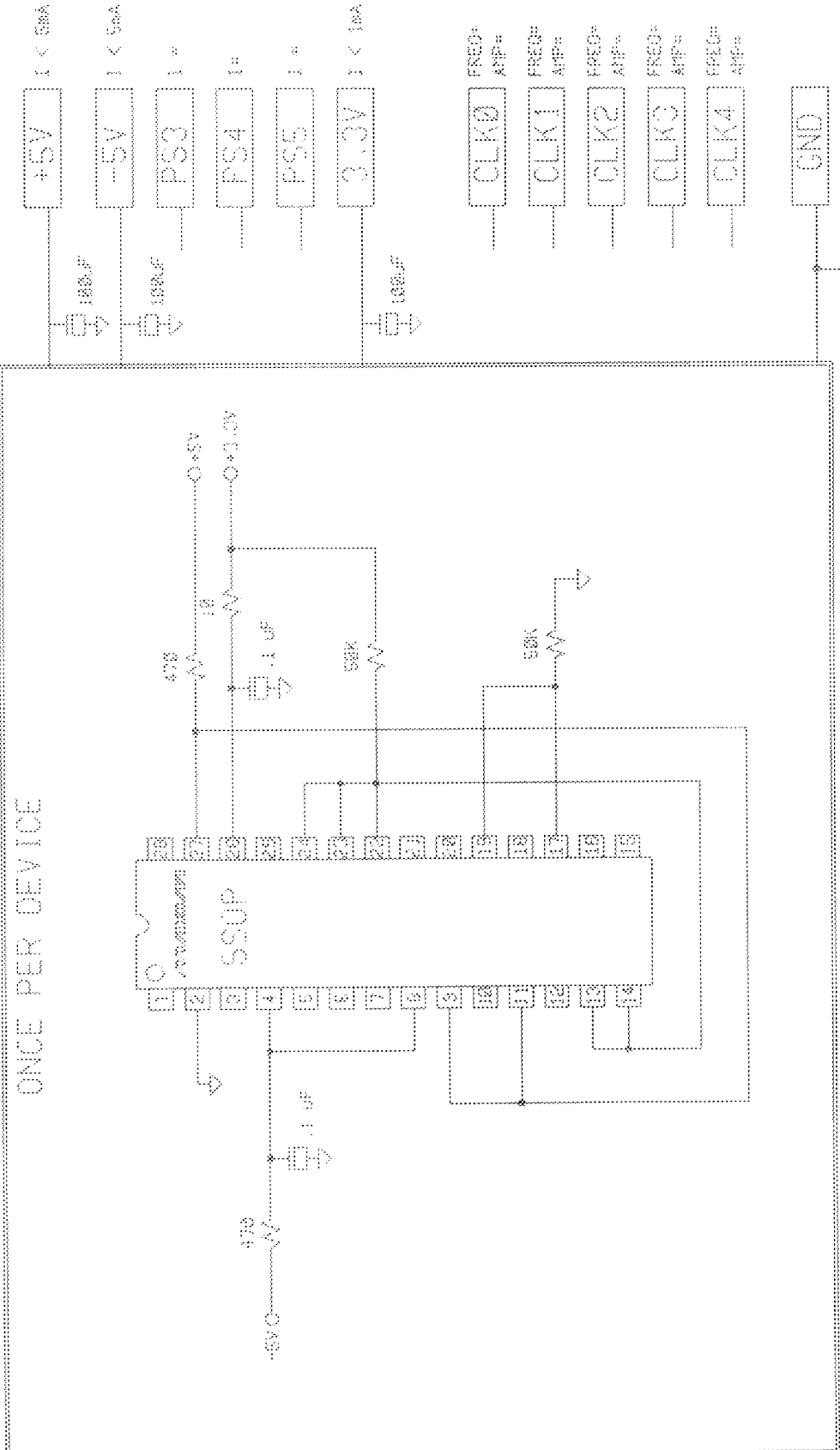

— STEADY STATE LIFE TEST IS PER MIL-STD-883 METHOD 1065.
 — BURN-IN IS PER MIL-STD-883 METHOD 1015, COND. B

<p>NOTES:</p> <ol style="list-style-type: none"> TEMPERATURE: 125C OR EQUIVALENT TIME: 100 HOURS MIN. OR EQUIVALENT ALL COMPONENTS AND MATERIAL MUST STAND 150C CONTINUOUS APPROVED FOR D33 COMMERCIAL EX 10/7/99 	<p>SPEC. NO. 06-5198 REV. A</p>	<p>MAXIM BURN-IN SCHEMATIC</p>
<p>DATE: 4/29/96</p>	<p>DEVICE TYPE(S):</p>	
<p>DRAWN BY:</p>	<p>MAX3237 / 3238</p>	