

Designing an Efficient and Low-Noise Power Supply for Sensors and Encoders

*By Anthony T. Huynh, Principal Member of the Technical Staff,
Applications, Industrial Power*

August 2019

Abstract

Smart, accurate sensors and encoders are bringing new levels of intelligence to automated industrial equipment. Indeed, the smart factory is being realized across a variety of manufacturing landscapes, enhancing productivity and efficiency. Enabling these compact sensors and encoders to perform reliably requires a high level of power efficiency. This paper discusses why conventional power management solutions aren't adequate for these types of applications and highlights newer technology that is up to the challenges.

Introduction

Next-generation systems, from industrial internet of things (IIoT), factory automation, defense electronics, and network infrastructure equipment to medical and consumer devices, all need to measure, collect, synthesize, and act upon data. The fourth industrial revolution, commonly referred to as Industry 4.0, impacts the current trend of automation and data exchange in manufacturing where cyber-physical systems, the IIoT, cloud computing, and cognitive computing all operate together.

Today smart, accurate sensors and encoders are widely used and have infused electronic equipment with new intelligence, transforming them to a state where they can communicate and cooperate with each other with high precision and with humans in real time and make decentralized decisions. This new intelligence requires low noise, yet higher

power in ever-shrinking spaces without impacting the thermal budget, making conventional power solutions unviable.

This paper examines in detail the limitations of conventional power solutions for smart sensors and encoders and introduces a newer solution that meets the trending requirements.

Sensors

Old-School Sensors Review

Historically, a sensor included a sensing element and some way to get the sensing data to the programmable logic controller (PLC). Data was often transferred in analog format and was unidirectional (sensor to master only). Analog data communication is prone to noise, and there is no way for the controller to diagnose, re-configure, or recalibrate the sensor directly.

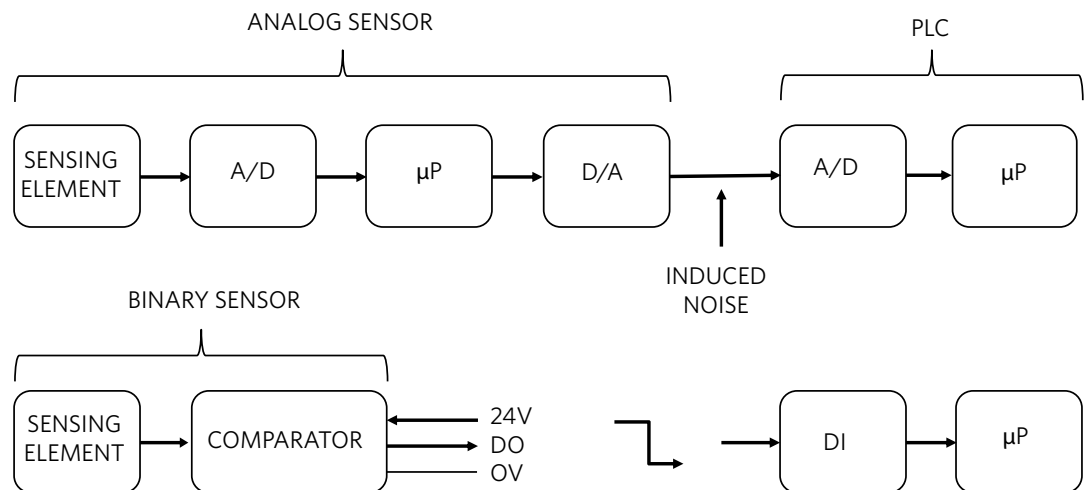

Figure 1. "Old-school" analog and binary sensors.

These analog sensors worked, but as technology advanced, sensor manufacturers integrated more functionality into sensors, reducing noise susceptibility with the introduction of binary sensors. Binary sensors are governed by the IEC 60947-5-2 standard. But data is still limited to unidirectional communication from the sensor to the master, has no error control, and still requires a technician on the factory floor for tasks such as manual calibration.

Smart Sensors

A better solution was needed to meet the demands of “Industry 4.0,” smart sensors, and reconfigurable factory floors. The solution is the IO-Link® industrial communications networking standard. IO-Link enables intelligence at the edge of the factory floor, allowing bi-directional communication between sensors and the controller. The system can adjust, configure, and diagnose sensors in real time.

A traditional factory is typically built and optimized for a single product. Once the product quota is met or if the market demand decreases, the factory sits idle. Reconfiguring this traditional factory to

make another product requires additional time and money. A smart factory, on the other hand, enables efficient, on-the-fly reconfiguration to quickly adapt to market demand fluctuations. With real-time diagnostics, predictive maintenance is possible and factory uptime is maximized. All these benefits are possible now with IO-Link, smart sensors, encoders and other technology advancements mentioned earlier.

Smart Sensors Design Challenges

Some main features of a smart sensor are: IO-Link compliance, full field configurability, real-time diagnostics, and small size (in order to be ubiquitous). These smart features increase power dissipation in sensors. At the same time, there is a surging trend toward miniaturization among various manufacturers. To power these wonderful sensors, designers face two big challenges: **heat** and **size**, while maintaining low noise and high power supply rejection ratio (PSRR) so as not to adversely affect the sensor output’s accuracy.

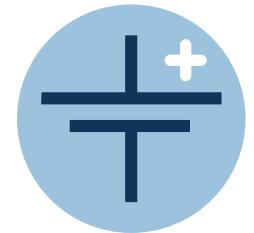

With IO-Link, the system can adjust, configure, and diagnose sensors in real time

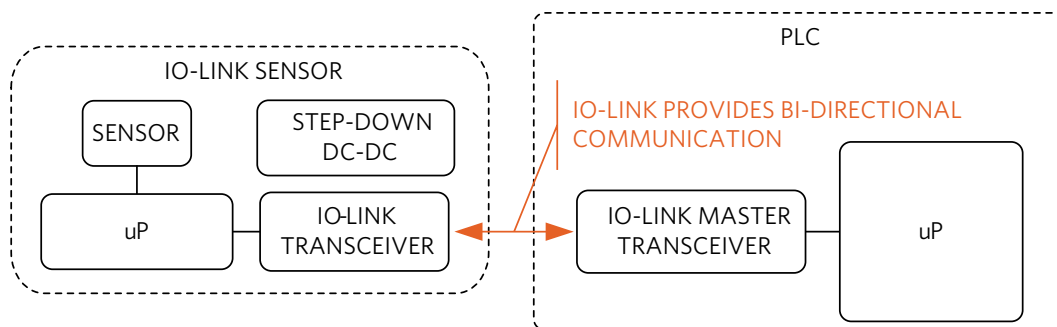

Figure 2. PLC with IO-link sensor.

Encoders

Encoders are used to electronically monitor the position of a rotating shaft. Absolute encoders provide precise position control in packaging, robotics, pick-and-place, lead/ball screw, rotary table positioning, and component insertion applications. Incremental optical encoders provide lower cost and smaller physical size for high-frequency and high-resolution applications. Incremental encoders are normally used to monitor speed and direction, but can also monitor position with additional software/hardware implementation.

Encoders reside in a small area located in motors or around the motor shaft. They share similar power supply design challenges with smart sensors: **heat** and **size**, while maintaining low noise and high PSRR so as not to adversely affect the encoder output's accuracy.

Design Example - Powering Miniaturized Smart Sensors and Encoders

Let's look at a smart proximity sensor with IO-Link. Figure 3 illustrates this sensor block diagram. The microcontroller (MCU) collects data from the sensing element, linearizes and calibrates it, and sends it to the IO-Link transceiver, where the data is then sent to the system PLC. The IO-Link connector also provides 24V to power the sensor.

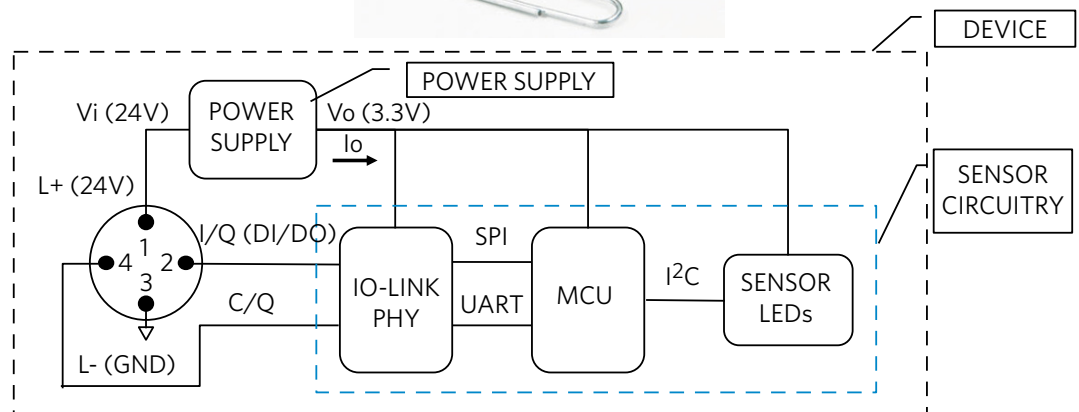
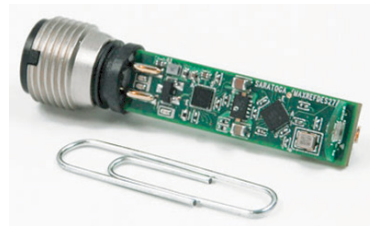

Figure 3. Simplified block diagram of a smart proximity sensor with IO-Link.

To facilitate our power design discussion, let's group all sensor elements into the category of "sensor circuitry." The "power supply" is the power solution used to convert 24V to 3.3V, which, in turn, powers our sensor circuitry. We'll simply call the physical sensor the "device."

Let's look at the power dissipation of the sensor circuitry, power supply, and total device using a low drop-out linear regulator (LDO), a traditional power solution. See Figure 4.

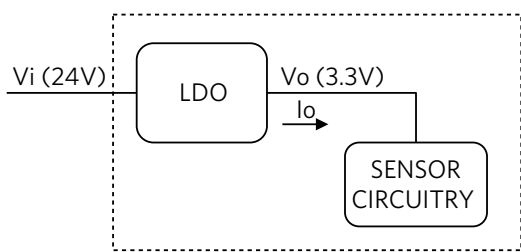

Figure 4. LDO - traditional power solution for a sensor.

Old-school analog sensor circuitry typically consumes about 15mA. The 24V industrial power rail can reach 30VDC maximum. The power dissipation levels are:

$$I_o = 15\text{mA}, V_i = 30\text{V (MAXIMUM)}, \\ V_o = 3.3\text{V}$$

$$P_{\text{Sensor}} = V_o \times I_o = 50\text{mW}$$

$$P_{\text{SUP}} = P_{\text{LDO}} = (V_i - V_o) \times I_o = 400\text{mW}$$

$$P_{\text{Device}} = P_{\text{Sensor}} + P_{\text{LDO}} = 450\text{mW}$$

In this example, only 50mW is used to do real work (powering the sensor circuitry), while 400mW is lost in the LDO due to its inefficiency. 450mW is the total power that our device must dissipate.

Now, as more features are added to make the sensor smarter, this demands more current, which will worsen the device's power dissipation. For example, if the sensor circuitry current increases to 30mA, following a similar calculation as above: $I_o = 30\text{mA}$, $P_{\text{Sensor}} = 100\text{mW}$, $P_{\text{SUP}} = 800\text{mW}$, and $P_{\text{Device}} = 900\text{mW}$. 900mW exceeds the power dissipation capability of most small proximity sensors.

HEAT: The Biggest Issue for Your Design

Heat is the biggest issue for your sensor design. Figure 5 shows power dissipation figures of the last two examples where LDO power dissipation dominates. The LDO's excessive power dissipation limits how much current the sensor circuitry can have, thus inhibiting innovation. At 15mA sensor current, the power dissipation barely fits within an M8 connector size, which has about a 450mW thermal dissipation limit. At 30mA sensor current, not even a larger M12 can tolerate the heat dissipation of 900mW. On the other hand, the LDO offers excellent PSRR, which is important to provide the sensor (as well as encoder) circuitry a low-noise supply voltage for accurate operation.

TYPICAL SENSOR MAXIMUM ALLOWED POWER DISSIPATION (THERMAL LIMITATIONS)

- M12 ~650mW MAX
- M8 ~450mW MAX



SENSOR AND POWER SUPPLY POWER DISSIPATION (mW)

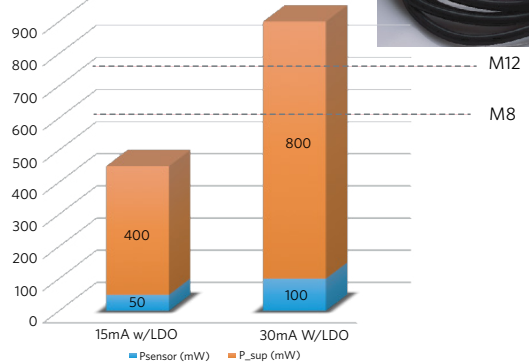
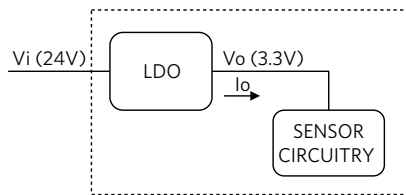

Figure 5. Power dissipation versus sensor thermal capability.

Clearly, we need to have a more efficient power solution to meet the thermal dissipation limit, while maintaining low-noise output voltage. Figure 6 shows a DC-DC converter solution followed by an LDO. The DC-DC converter provides high efficiency, which reduces heat dissipation, while the LDO provides excellent low-noise output. The DC-DC converter's 5V output keeps the LDO close to its drop-out limit and significantly reduces its power dissipation.

At 30mA sensor current, and with an 85% efficiency, the DC-DC converter dissipates only 26mW while the LDO dissipates only 50mW. Total device power dissipation (including sensor power dissipation of 100mW) is 176mW. Compared with the 900mW power dissipation of the traditional LDO solution, the (DC-DC + LDO) solution dissipates only 20%, or 5x less power.



$$I_o = 30\text{mA}, V_i = 30\text{V(MAX)}, V_o = 3.3\text{V}$$

$$P_{\text{SENSOR}} = V_o \times I_o = 100\text{mW}$$

$$P_{\text{LDO}} = (V_i - V_o) \times I_o = 800\text{mW}$$

$$P_{\text{DEVICE}} = P_{\text{SENSOR}} + P_{\text{LDO}} = 900\text{mW}$$

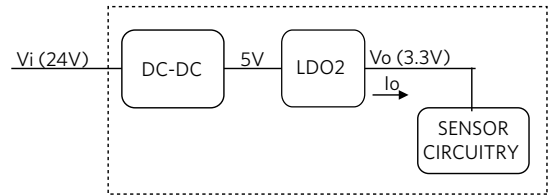

$$I_o = 30\text{mA}, V_i = 30\text{V(MAX)}, V_o = 3.3\text{V}, \eta = 85\%$$

$$P_{\text{SENSOR}} = V_o \times I_o = 100\text{mW}$$

$$P_{\text{LDO2}} = (5\text{V} - V_o) \times I_o = 50\text{mW}$$

$$P_{\text{DC-DC}} = (P_{\text{SENSOR}} + P_{\text{LDO2}}) \times (1/\eta - 1) = 26\text{mW}$$

$$P_{\text{DEVICE}} = P_{\text{SENSOR}} + P_{\text{LDO2}} + P_{\text{DC-DC}} = 176\text{mW}$$

Figure 6. Power supply dissipation – LDO versus (DC/DC + LDO).

SIZE – A Big Issue for Your Design Design

A smart system requires more smart sensors and encoders. Smart sensors and encoders must be small to be used everywhere. Thus, the power solution to power these devices must also be miniaturized. Maxim now offers a highly integrated power management IC that is designed to meet the tough requirements of IIoT applications. **MAX17671** integrates both the DC-DC converter and an LDO together in a space-efficient, 3mm x 3mm, 10-pin TDFN package, providing a good option for smart sensors and encoders.

MAX17671 takes a wide input voltage from 6.5V to 60V and produces an efficient 5V output, which in turn drives the integrated LDO to provide a low-noise 3.3V output to power the sensor/encoder circuitry. Figure 7 shows a MAX17671 typical application circuit.

Figure 8 shows the typical efficiency performance of MAX17671. At 30V input, 200kHz, 5V output voltage, and 50mA output current, the IC achieves approximately 88% efficiency. Figure 9 shows the efficiency for the same conditions but at a higher switching frequency of 600kHz. The higher switching frequency offers a smaller output inductor and capacitor, which saves space but has some efficiency tradeoffs.

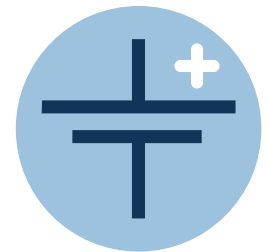

*New solution
reduces total
device power
dissipation
by 5x*

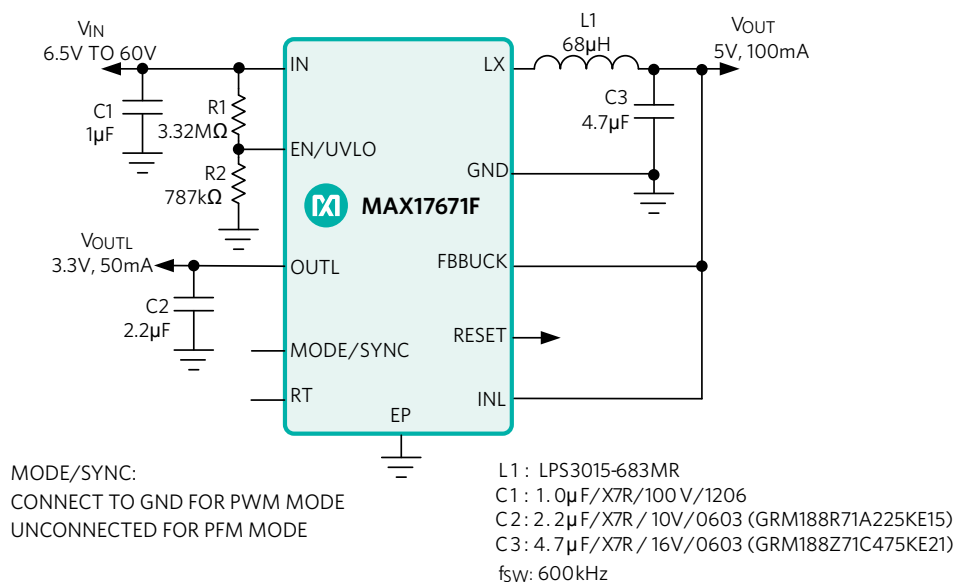

Figure 7. MAX17671 typical application circuit schematic (3mm x 3mm, 10-pin TDFN package).

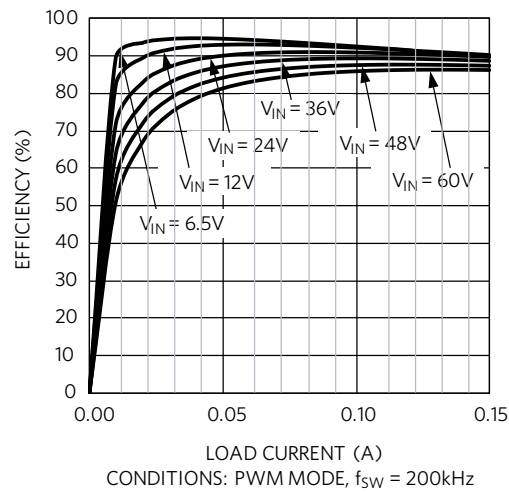

Figure 8. MAX17671 DC-DC converter 5V output efficiency at 200kHz.

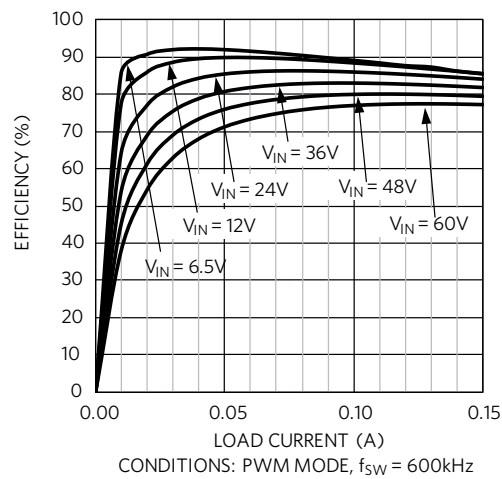

Figure 9. MAX17671 DC-DC converter 5V output efficiency at 600kHz.

Figure 10 shows the MAX17671 DC-DC converter 5V output voltage ripple of 12mV peak-to-peak at 600kHz switching frequency. Figure 11 shows the MAX17671 3.3V LDO output PSRR of approximately 45dB, or 178x noise reduction. So, the 12mV peak-to-peak output ripple is filtered down to 67 μ V peak-to-peak, a very low noise figure to assure no adverse effect to sensor and encoder accuracy.

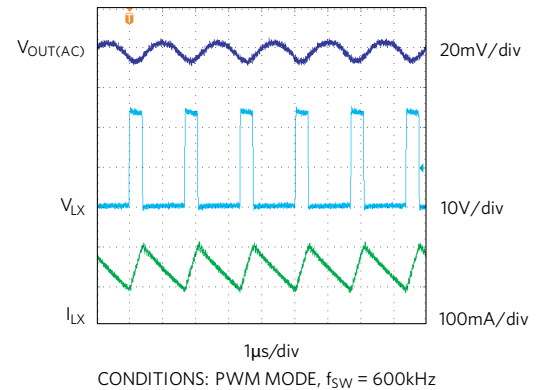

Figure 10. MAX17671 DC-DC converter 5V output voltage ripple at 600kHz.

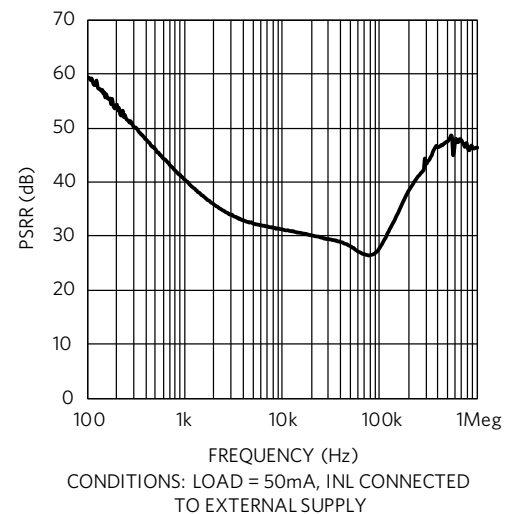

Figure 11. MAX17671 LDO 3.3V output PSRR versus frequency.

Summary

Industry 4.0 drives demand for smart sensors and encoders, which must be tiny in order to be ubiquitous. The sensors and encoders must also be more accurate, which requires a low-noise power supply. Traditional power solutions using LDOs offer excellent low-noise performance, but have excessive power dissipation, creating heat problems. Sensor designers face two big challenges in terms of heat and size, while maintaining low noise performance. To solve these challenges, the power solution must be highly efficient, miniaturized, and provide low noise. The compact yet highly integrated MAX17671 DC-DC converter with integrated LDO provides an example of a new power-supply solution that meets these stringent requirements.

For more information, visit:

www.maximintegrated.com