

Achieve High-Accuracy Temperature Measurement in Your Precision Designs

Introduction

In pharmaceutical processing, inaccurate temperature conditions and measurements could ruin an entire batch of products. For example, a misread of the pharmaceutical process temperature could produce improper medical mixtures, compromising the quality of medicine and jeopardizing the overall production cost, thus causing losses exceeding hundreds of thousands of dollars. In precision industrial systems such as this, it is extremely important to know the exact temperatures of the chemicals.



Figure 1. Pharmaceutical Monitoring System

Common Temperature Sensors

It is important to understand the characteristics and limits for various temperature sensors to make the best choice for your application. Commonly available temperature sensors include the resistance temperature detector (RTD), pyroelectric device, silicon transistor or diode, thermocouple, thermopile, thermistor, and silicon thermometer (Figure 2).

The RTD and thermistor temperature sensing elements change resistive values with temperature changes. The platinum RTD has a relatively positive linear temperature coefficient of $0.00385\Omega/\Omega/^\circ\text{C}$.

In contrast, the high-resistance negative temperature coefficient (NTC) thermistor has a fairly nonlinear temperature

coefficient and a limited temperature range. The nonlinearity of the thermistor makes it challenging to achieve a high level of accuracy.

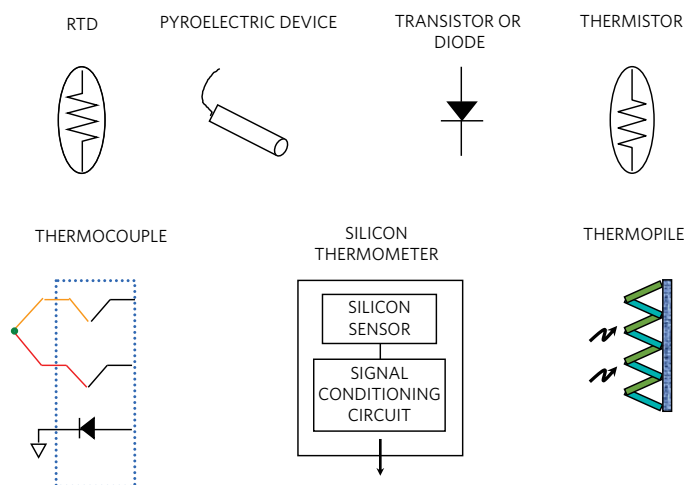

Figure 2. Common Temperature Sensors

The construction of the thermocouple is metal to metal. The electromotive force (EMF) output of a thermocouple is in millivolts instead of resistance and is nonlinear. The major advantage of the thermocouple, as well as the pyroelectric device, is that it can sense extremely high temperatures. The thermocouple produces EMF microvolts per degree Celsius output signals. Because of the small output voltage changes, the thermocouple signal chain is prone to EMI and IC device noise. Therefore, high-accuracy thermocouple designs can be challenging.

The diode and signal thermometer are both silicon based, providing linear response that is better than the RTD sensor. Since this temperature sensor exists in silicon, the temperature range is limited from -55°C to $+150^\circ\text{C}$.

The RTD is a perfect sensor for the pharmaceutical precision application. The four characteristics that separate the RTD from the others are stability, accuracy, better linearity than thermocouples and thermistors, and a wide temperature range.

The RTD Sensor

There are several varieties of RTD resistive material, such as nickel (Ni), copper (Cu), or platinum (Pt). The more common RTD material is platinum because of its chemical stability and relatively linear response to temperature changes.

Platinum RTDs are available in a variety of 0°C resistive values, however the 100Ω (PT-100) and 1000Ω (PT-1000) are most common across applications. Because of this popularity, the [MAX31865](#); RTD-to-digital-converter, accommodates both RTD resistance values.

The resistances over temperature of these elements are very stable with a temperature coefficient of 0.003925Ω/Ω/°C. The RTD resistive response, with some curvature, closely matches a straight-line approximation (Figure 3).

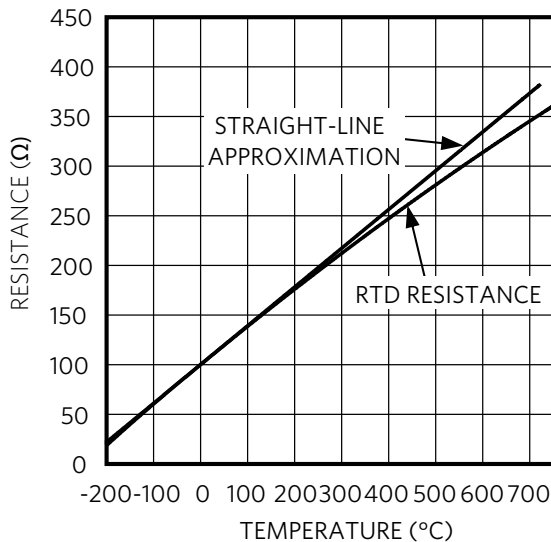

Figure 3. PT-100 RTD Resistance vs. Temperature

The linearity of the RTD element is predictable and can be described with the Callendar-Van Dusen equation (Eq. 1).

$$R(T) = R_0 (1 + aT + bT^2 + c(T - 100) T^3) \text{ (Eq. 1)}$$

In this equation, $R(T)$ is equal to the RTD resistance over temperature, R_0 is RTD resistance at 0°C, and T is the temperature in degrees Celsius. Additionally,

$$a = 3.9083 \times 10^{-3}$$

$$b = -5.775 \times 10^{-7}$$

$$c = -4.18301 \times 10^{-12} \text{ for } -200^\circ\text{C} \pm T \pm 0^\circ\text{C}$$

$$c = 0 \text{ for } 0^\circ\text{C} \pm T \pm +850^\circ\text{C}$$

Using the Callendar-Van Dusen equation, the maximum RTD end-point linearity error, whether you use the PT-100 or the PT-1000, is approximately 4.34% (Figure 4).

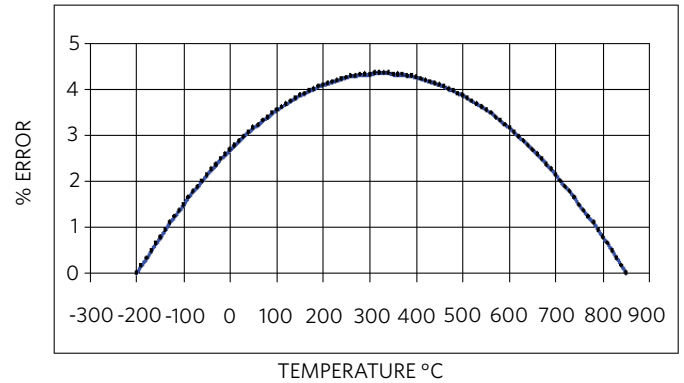

Figure 4. PT-100 RTD Linearity Error vs. Temperature

The RTD resistance (as it changes with temperature) can be difficult to sense given cable impedance. Reasonable values for the cable resistance (R_{CABLE}) can be as high as 50Ω (Figure 5).

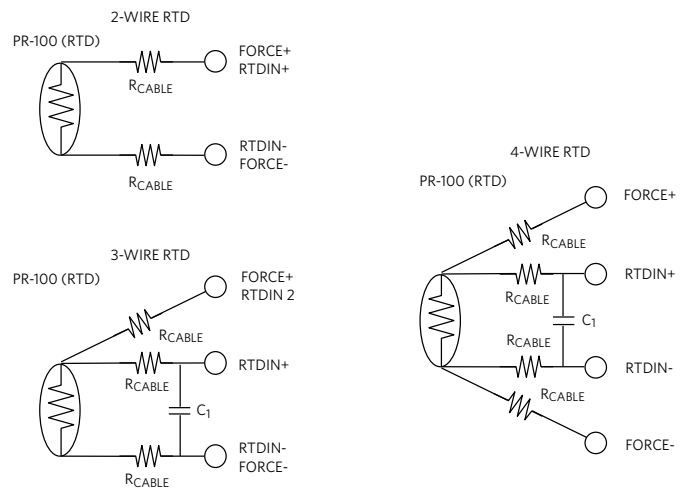

Figure 5. 2-Wire, 3-Wire, and 4-Wire PT100 RTD Configurations with MAX31865 Pin Connections

The overtemperature resistor range of PT-100 is from 18.52Ω at -200°C to 390Ω at +850°C. With this RTD resistor range, it is easy to see that the 2-wire RTD and 10Ω cable resistance creates ~25°C error across the entire temperature range. Additionally, the temperature coefficient of the cable or lead can further contribute to measurement errors.

The 3-wire and 4-wire RTD hardware implementations significantly reduce these errors.

Implementing the RTD System

There are several ways to implement the RTD sensing circuit, including the discrete design approach or the fully contained integrated approach.

The discrete design requires a precision amplifier and current source (Figure 6).

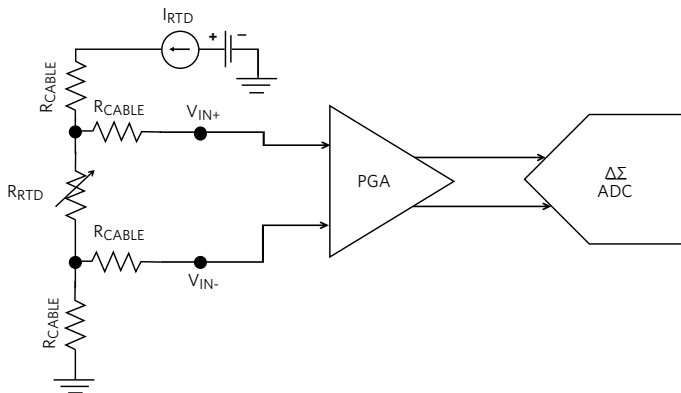

Figure 6. Example Discrete 4-Wire RTD Circuit

This RTD system measures temperature over a wide range of -200°C to +850°C. The design uses an RTD in a 4-wire configuration. The current source (I_{RTD}) excites the 4-wire RTD. The differential voltage that develops across the RTD is gained by the programmable-gain amplifier (PGA). The signal is then converted into a digital output code.

This system can accurately measure the RTD change in resistance, however, there are three components (PGA, I_{RTD} , and $\Delta\Sigma$ ADC) and there is no accommodation for error conditions. Additionally, in this circuit there is no overvoltage input-protection or RTD-connection fault detections.

The Integrated System

The RTD, in conjunction with the MAX31865 RTD-to-digital converter, provides a complete solution. This device is well suited for high-precision applications by providing a 0.03125°C resolution across a -200°C to +850°C temperature range, with a 0.5°C level of accuracy (Figure 7).

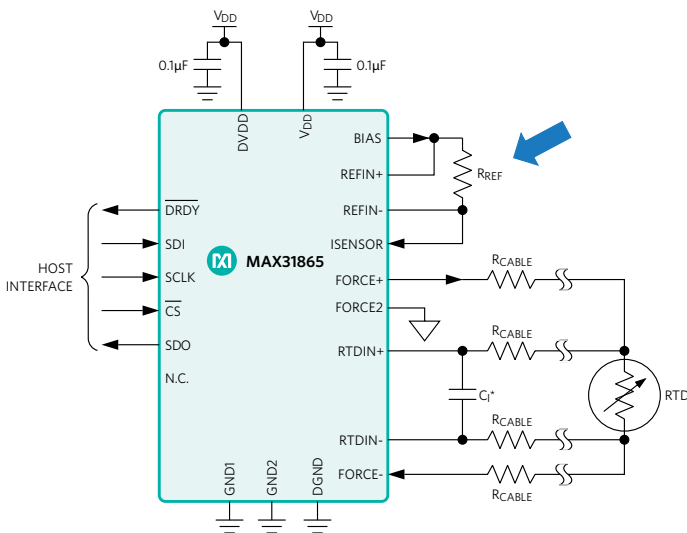

Figure 7. MAX31865 3-Wire RTD Sensor Connection

In this complete system, the MAX31865 performs error-checking, prevents input overvoltages, and filters 50Hz or 60Hz line signals.

The MAX31865 is effectively positioned to interface directly to the RTD sensor. The MAX31865 builds a voltage-divider between the RTD and external precision resistor, R_{REF} (see the blue arrow in Figure 7). This circuit does not need an exact current source, rather the RTD current is a byproduct of the R_{RTD}/R_{REF} ratio. With the MAX31865, the derivation of the RTD resistance value is easy (see Eq 2).

$$R_{RTD} = \frac{(ADC\ CODE \times R_{REF})}{2^{15}} \quad (Eq. 2)$$

Where R_{REF} is the reference resistor in Figure 7.

The MAX31865, designed to accommodate the 2-/3-/4-wire RTD configurations, offers an elegant solution. Now the precision is dependent on a single discrete resistor, R_{REF} . A 15-bit $\Delta\Sigma$ ADC acquires the RTD sensor resistance. To further improve the accuracy of the RTD sensing element, use the Callendar-Van Dusen calibration equation (Eq. 1).

The MAX31865 conversion engine is a 15-bit $\Delta\Sigma$ ADC. With the signal conditioning circuit implemented primarily as a digital circuit, the MAX31865 RTD-digital converter provides:

1. Repeatable Results
 - The stability of this system is dependent on the R_{REF} and RTD resistor ratio and the low noise characteristics of a $\Delta\Sigma$ ADC.
2. Input Protection
 - The RTD input pins (FORCE+, FORCE2, FORCE-, RTDIN+, and RTDIN-) are protected against high voltages of up to $\pm 45V$. Analog switches open when the applied external voltage is greater than $V_{DD} + 100mV$ or less than $V_{GND1} - 400mV$.
3. Fault Detection
 - Identifies conditions such as an open RTD element, input pins tied to ground or V_{DD} , or inputs shorted together.
4. 50Hz or 60Hz Rejection Capability
 - The MAX31865's internal $\Delta\Sigma$ ADC has a Sinc digital filter that is programmable to reject a frequency of 50Hz or 60Hz.

Conclusion

Industrial temperature measurement circuits such as pharmaceutical systems require a highly accurate temperature sensor and precision ADC. The selection of the temperature sensor type is critical, however, the ability to utilize the output signal of the sensor is paramount.

The ideal temperature sensor for this application is the RTD. RTDs are commonly used because of their accuracy, stability, and wide temperature range. The easy-to-use MAX31865 RTD-to-digital converter captures the small RTD resistance value to provide a repeatable, precise digital-to-temperature conversion, with accuracy of 0.5°C.

The MAX31865 is well-suited for these tasks, with a built-in RTD interface and a 15-bit $\Delta \Sigma$ ADC. This device has numerous error correction mechanisms, which insures a stable and reliable conversion result. The MAX31865 has a the 0.5°C accuracy over a -200°C to 850°C range to service these more critical temperature challenges.

Glossary

RTD: Resistance temperature detector

PGA: Programmable gain amplifier

NTC: Negative temperature coefficient

EMF: Electromotive force

Ni: Nickel

Cu: Copper

Pt: Platinum

R_{CABLE}: Cable resistance

Learn more:

[Tutorial 4679: Thermal Management Handbook](#)

[Application Note 6262: RTD Measurement System Design Essentials](#)

[MAX31865 RTD-to-Digital Converter](#)

Design Solutions No. 67

Rev 0; September 2017

Need Design Support?
Call 888 MAXIM-IC (888 629-4642)

[Find More Design Solutions](#)

Maxim Integrated
160 Rio Robles
San Jose, CA 95134 USA
408-601-1000

maximintegrated.com/design-solutions

