

## Choose the Right RS-485 Transceiver to Save Space, Reduce Cost, and Maximize ESD Protection

### Introduction

RS-485 continues to be the physical layer workhorse for reliable data transmission in a wide diversity of applications. An evolving environment means that the physical implementation must adapt to the availability of lower input voltages and more stringent ESD specifications, while remaining cost effective. In this article, we will discuss the challenge of meeting these requirements and will propose a highly integrated solution. This solution manages to hit the sweet spot between cost and performance for applications requiring mid-grade levels of electro-static device (ESD) protection.

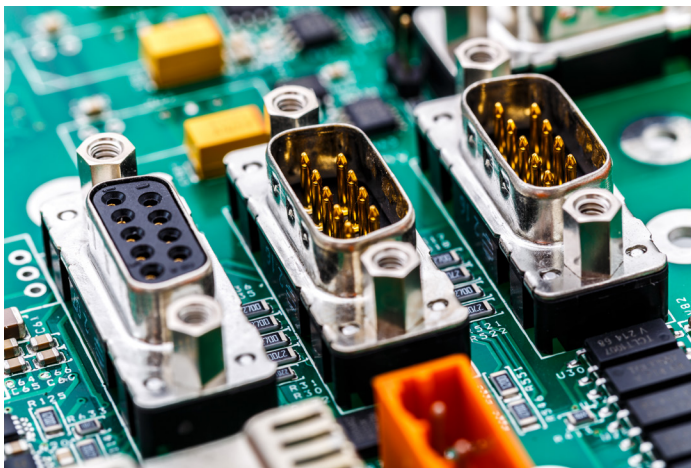

Figure 1. DE9 Connector for RS-485 Serial Communication

### The RS-485 Standard

RS-485 is a serial interface standard which provides single path differential signaling over two lines for data transmission over distances up to 4000 feet and speeds up to 20Mbit/s. The interface can be used in simplex, or half-duplex, mode with a single-pair cable. Full-duplex operation with simultaneous transmit and receive is implemented with a two-pair cable. The robust RS-485 standard is useful in noisy environments such as factories, process control plants and utility sites. Figure 2 illustrates a half-duplex transceiver system.

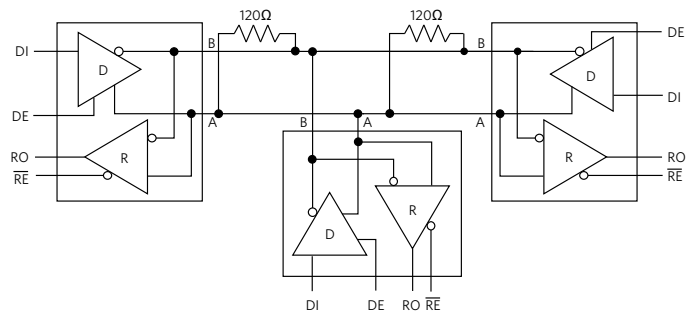

Figure 2. Half-Duplex Transceiver System

### Low Voltage Operation

The majority of RS-485 integrated circuits (ICs) available today require a 5V supply voltage. With the 5V rail becoming less common, a redesign of the chip architecture to operate with a 3.3V power supply is a necessity. Operation at 3.3V provides significant power-savings compared to 5V operation. Internal regulated positive and negative charge pumps assure compliance with  $\pm 5V$  standard requirements. They also provide improved noise immunity compared to previous generations relying on unregulated charge pumps.

### ESD Standards

Two methods are commonly used for testing the ESD susceptibility of integrated circuits. The MIL-STD-883 human body model (HBM) test—referenced in JEDEC JS-001—was developed as an aide for understanding the precautions necessary for packaging and handling ICs. The applied signal in this test is a current waveform derived from a circuit that simulates the capacitance and source impedance of a typical human body. The second, more stringent method for testing ICs—IEC 61000-4-2 (formerly IEC 1000-4-2)—specifies ESD testing both by contact discharge and by air discharge (Figure 3).

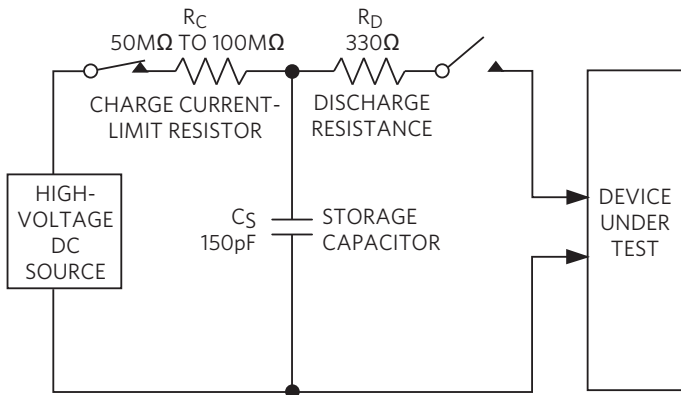

Figure 3. IEC 61000-4-2 ESD Test Model

### Protection methods

To protect against ESD, a designer can either add protection externally (Figure 4) or choose ICs with high levels of protection built in. Transient voltage suppression (TVS) devices, including metal-oxide varistors and silicon avalanche suppressors such as the TransZorb, are effective but expensive. External ESD protection also consumes valuable board area and adds capacitance to the I/O line.

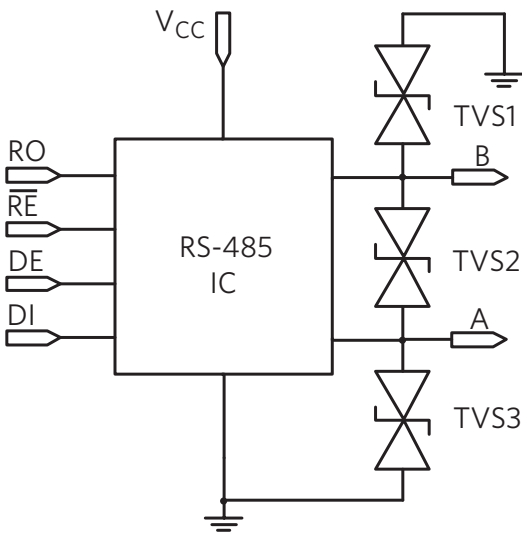

Figure 4. Transceiver Chip ESD Protected With External Diodes

To overcome these limitations, Maxim Integrated was the first to integrate protection into transceiver ICs, enabling solutions that occupy minimum board space and eliminate costly external components.

### MAX3483AE 3.3V, ±20kV ESD Protection

**MAX3483AE** is the first RS-485 transceiver to operate from a 3.3V supply and include ESD protection up to ±20kV HBM. Providing ±5kV more protection than competitive devices, MAX3483AE offers the highest protection in its class.

This half-duplex transceiver (Figure 5) is optimized for extended cable runs in noisy environments. By considering the tradeoff between data rate and cable length, MAX3483AE allows you to design a system that operates over cable lengths of hundreds of meters, without repeaters. The receiver features a unit-load input impedance, allowing up to 32 devices on a single bus. MAX3483AE also includes a fail-safe receiver, ensuring that the receiver output (RO) is high when inputs are shorted, open, or connected to a tristate bus. In addition to ±20kV HBM ESD protection, all transmitter outputs and receiver inputs are protected to ±15kV air-gap ESD and ±8kV contact ESD in accordance with IEC 61000-4-2. The MAX3483AE is available in the industry standard 8-pin SO package.

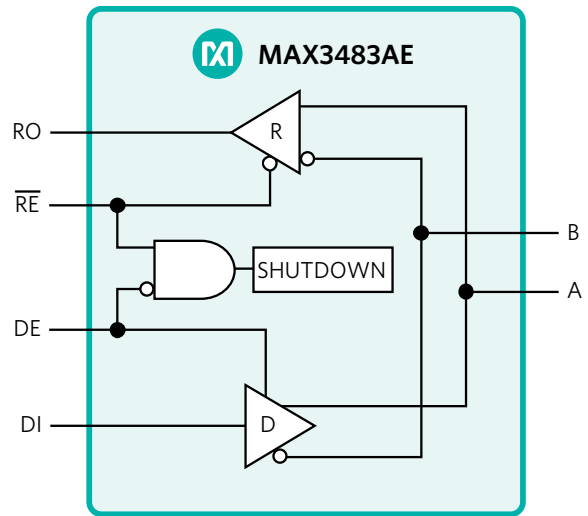

Figure 5. MAX3483AE Block Diagram

### The MAX34xxAE Family of Transceivers

The MAX3483AE is complemented by four other members of the family, covering different configurations, speeds and packages (Table 1).

	Configuration	Data Rate (Max)	Package
MAX3483AE	Half Duplex	250kbps	SO8
MAX3485AE	Half Duplex	20Mbps	SO8
MAX3488AE	Full Duplex	250kbps	SO8
MAX3490AE	Full Duplex	20Mbps	SO8
MAX3491AE	Full Duplex	20Mbps	S014

Table 1. The MAX34xxAE family

## Conclusion

We have reviewed the challenge of providing reliable RS-485/RS-422 communication in a noisy environment, using a reduced input voltage source, while integrating ESD protection. The MAX3483AE and its related family or products meets this challenge and improves reliability by increasing the ESD protection to  $\pm 20\text{kV}$ . A unique combination of low voltage operation and high integration provides a compact and cost effective solution for the mid-grade ESD protection class of applications.

### GLOSSARY

**FULL-DUPLEX:** Transmission and reception of data can happen simultaneously, as in a phone conversation.

**HALF-DUPLEX:** The transmission of data in just one direction at a time, not simultaneous.

**HBM:** Human Body Model specified by MIL-STD-883 and referenced in JEDEC JS-001 for testing the IC ESD tolerance.

**MID-GRADE:** ESD protection between  $\pm 15\text{kV}$  and  $\pm 35\text{kV}$  ESD for HBM.

**PHYSICAL LAYER:** RS-485 is a physical layer standard. It defines the electrical characteristics of the transmitter and the receiver. On top of it, an application layer handles the communication protocol. Ethernet (up to 10Gbits/s) and USB (short distances) are protocols that define both the physical and application layer.

**RS-485:** The common name for the TIA/EIA-485 standard.

**RS-485 STANDARD:** Specifies differential signaling on two lines up to 4000 feet and up to 20Mbits/s.

**RS-422:** A variation of RS-485 with similar specifications but designed for one driver and up to 10 receivers.

**TRANSZORB:** A semiconductor protection device similar to a diode but with symmetrical conduction threshold vs voltage polarity. Based on the mechanism of volume avalanche in the silicon, it limits the voltage (for a given current) to a value lower than that of the Varistor.

**TVS:** Transient Voltage Suppressor

**UNIT LOAD:** The input impedance of the RS-485 receiver is specified as greater than or equal to 12 k $\Omega$ . This impedance is defined as having one-unit load (UL). The RS-485 standard specifies the capability to sustain up to 32 ULs.

**VARISTOR:** A semiconductor protection device similar to a diode but with symmetrical conduction threshold vs voltage polarity.

## Learn more

### Products:

[MAX3483AE Half Duplex, 0.25Mbps, +3.3V-Powered,  \$\pm 20\text{kV}\$  ESD-Protected, Slew-Rate-Limited RS-485/RS-422 Transceivers](#)

[MAX3485AE Half Duplex, 20Mbps, +3.3V-Powered,  \$\pm 20\text{kV}\$  ESD-Protected, Slew-Rate-Limited RS-485/RS-422 Transceivers](#)

[MAX3488AE Full Duplex, 0.25Mbps, +3.3V-Powered,  \$\pm 20\text{kV}\$  ESD-Protected, Slew-Rate-Limited RS-485/RS-422 Transceivers](#)

[MAX3490AE Full Duplex, 20Mbps, +3.3V-Powered,  \$\pm 20\text{kV}\$  ESD-Protected, Slew-Rate-Limited RS-485/RS-422 Transceiver](#)

[MAX3491AE Full Duplex, 20Mbps, SO14, +3.3V-Powered,  \$\pm 20\text{kV}\$  ESD-Protected, Slew-Rate-Limited RS-485/RS-422 Transceivers](#)

### Further Reading:

[Application Note: ESD Protection for I/O Ports](#)

[Application Note: Maxim Leads the Way in ESD Protection](#)

[Application Note: How Far and How Fast Can You Go with RS-485?](#)

[Tutorial: Choosing the Right RS-232 Transceiver](#)

Design Solutions No. 19

**Need Design Support?**

**Call 888 MAXIM-IC (888 629-4642)**

Maxim Integrated  
160 Rio Robles  
San Jose, CA 95134 USA  
408-601-1000  
[maximintegrated.com](http://maximintegrated.com)

